

SOME OBSERVATIONS OF FLOW PATTERNS AND STATISTICAL PROPERTIES OF THREE COMPONENT FLOWS

H. K. Kytömaa and C. E. Brennen
Division of Engineering and Applied Science
California Institute of Technology
Pasadena, California

ABSTRACT

Air-water flows, solids-water flows and three component air-solids-water flows in a vertical pipe have been investigated in a Three Component Flow Facility. Visual observations of the flow patterns show that the three component flow exhibits strong unsteady vortical motions which do not occur in the two phase flows studied. Quantitative results of the fluctuating component of the cross-sectionally averaged volume fraction measurements are presented, and related to the nature of the flows. The ratio of the steady component to the r.m.s. of the fluctuating component of the volume fraction measurement (Signal To Noise Ratio) is found to be a good flow structure indicator. Remarkably, the solids-water flows and the bubbly air-water flows exhibit almost identical signal to noise ratios for the same volume fraction. However, the corresponding values for the three component flows reflect greater fluctuations corresponding to the vortical structures.

1. INTRODUCTION

Due to the discrete nature of multicomponent flows, an issue which is often neglected in analytical models, the statistical properties of measured flow quantities have been shown to contain valuable information on the properties of the flow. The fluctuating component of the pressure drop in two phase flow through an orifice was used to derive the flow rates of the components by Ishagai et al (1). Jones and Zuber (2) used the probability density function of X-ray attenuation volume fraction signals as a flow pattern discriminator for vertical bubbly, slug and annular flows. Bernier (3) used the inherent noise of resistive volume fraction signals as the seed for his experimental analysis of

kinematic wave propagation in bubbly flows. The significance of the statistical properties of volume fraction measurements depends entirely on the size of the influence volume of the measuring device. For example, hot wire anemometers, optical probes and other devices have been employed to make point measurements of volume fraction. To obtain useful information, time averaging of the output is necessary. This limits the dynamic resolution of such a device. On the other hand X-ray and Gamma-ray attenuation techniques inherently carry out line averages along the beam. Capacitive and resistive measuring techniques yield a volume average of concentration. The size and shape of the measuring volume is determined by the geometry of the electrodes. With a large averaging volume good dynamic response is achieved at the cost of diminished spatial resolution.

Much of the research in vertical multicomponent flows has focused on low Reynolds number sedimentation and fluidization. Such three component flows have been visually observed to undergo a flow regime change from a dispersed state to one with segregated vertical streams of individual constituents (Fessas & Weiland (4)). In the work presented here, Reynolds numbers of 1000 and 400 were measured for individual bubbles and particles respectively based on terminal velocity. A change in flow regime was also seen to take place in these flows. Departure from dispersed flow was observed with increased solids and air volume fractions resulting in an agitated unsteady flow with air slugs.

This study uses a volume averaging non-intrusive volume fraction meter to analyze the statistical properties of three-phase flows and compares them with the properties of the constituent two-phase flows. The resistive volume fraction measuring technique employed has good dynamic resolution. The statistical nature of the volume fraction is represented by the Signal To Noise Ratio (STNR) of the output signal. We find remarkable similarities in the STNR for dispersed bubbly and slurry flows. Hence the STNR could be used as a simple and accurate independent indicator of the volume fraction. Also the STNR in conjunction with the mean volume fraction proves to be a good flow regime discriminator in two and three component flows.

2. EXPERIMENTAL FACILITY AND INSTRUMENTATION

The Three Component Flow facility (TCFF) at Caltech, shown in figure 1 was used to study the statistical properties of volume fraction signals in bubbly, slurry and three component flows. The test section is a vertical clear acrylic pipe .1016 meters (4 inches) in diameter and 2.2 meters in length. The air-water flows are formed by introducing the gas through an injector situated inside the vertical pipe, .5 meters below the test section. The injector consists of an array of twelve 3.2 mm (1/8 inch) diameter brass tubes perforated with .4 mm (1/64 inch) holes. An 8 atm (120 psi) compressed air line supplies the injector through a regulator, an orifice plate flow meter (to monitor air mass flow), valves to control air flow and a manifold to distribute the air flow evenly among the brass tubes.

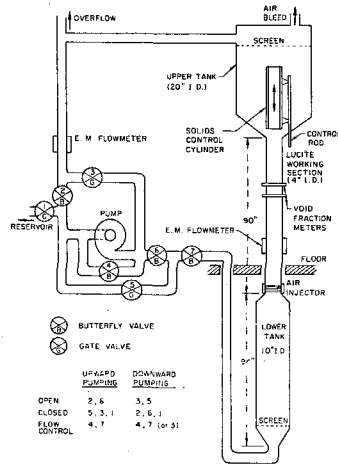

FIGURE 1 Schematic of the Three Component Flow Facility.

The slurry flows studied consist of water and polyester particles that are cylindrical in shape, with a mean diameter of 3 mm. A mixture of equal density black and white particles is used for flow visualisation. The most novel aspect of the facility is its ability to handle solids and to control their flow rate independently of the liquid without having to add or remove solids from the system. When at rest prior to an experiment the solids are trapped between a vertical 4 inch control cylinder and the storage hopper. As the control cylinder is raised from the reducer on top of which it sits, the gap created allows particles to enter the test section under the action of gravity. The vertical position of the control cylinder can be varied by means of a control rod attached to a worm gear mechanism and this permits the solids flow rate to be controlled by varying the gap between the cylinder and the reducer. To recycle the solids after an experiment the control cylinder is lowered to the closed position and sufficient upward water flow is generated to fluidize the solids in the lower tank and to carry them back to the hopper where they settle into their original position.

The static pressure gradient in the test section is monitored using an inductive differential pressure transducer. The volume fraction of the dispersed medium is measured using an Impedance Volume Fraction Meter (IVFM). The IVFM was developed by Bernier (3). It has been modified for temperature compensation and now has a shielded electrode configuration which decreases the axial extent of the influence volume over which the measurement is carried out. The active stainless steel electrodes which are flush mounted into a section of pipe are 6.4 mm in axial length and form diametrically opposed 90 degree arcs on the circumference of the pipe. The active electrodes are each sandwiched between two shielding electrodes. These are 9.5 mm in axial length and also form 90 degree arcs. Figure 2 shows the electrode configuration. The shielding electrodes duplicate the active electrode potential through a high input impedance voltage follower. The IVFM is excited at an amplitude of .3 volts r.m.s. and a frequency of 40 KHz at which the impedance is found to be primarily resistive. The excitation and signal processing equipment is described in more detail by Bernier (3).

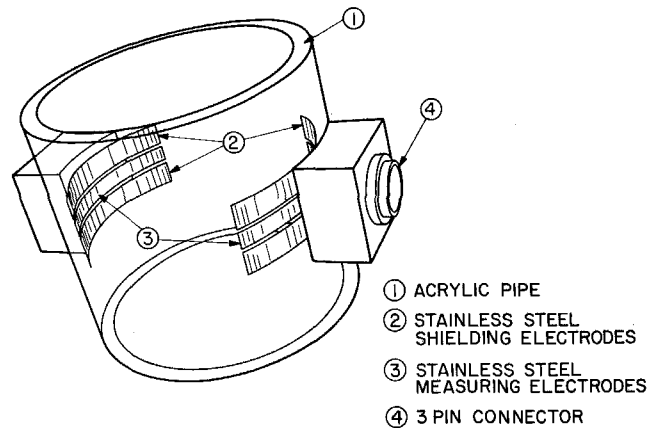

FIGURE 2 Isometric view of the Impedance Volume Fraction Meter electrodes showing the stainless steel circular arc electrodes flush mounted in a piece of acrylic pipe.

The IVFM is calibrated with both bubbly and particulate flows against the volume fraction obtained from the static pressure gradient measurement. These two plots are shown in figures 3 and 4. Equations 1 and 2 are the respective linear regression fits to the calibrations. The corresponding correlation coefficients for these fits are .9992 and .997. The discrepancy between the two fits (up to 4 %) is attributed to experimental error in the measurement.

$$\alpha(\%) = 6.53 \text{ IVFM(VOLTS)} - .006 \quad (1)$$

$$V(\%) = 6.77 \text{ IVFM(VOLTS)} - .41 \quad (2)$$

The IVFM is found to have excellent linearity up to volume fractions of at least 40 %. With a sensitivity of .15 Volts per percent of volume fraction, the passage of individual bubbles (or particles) is readily detectable.

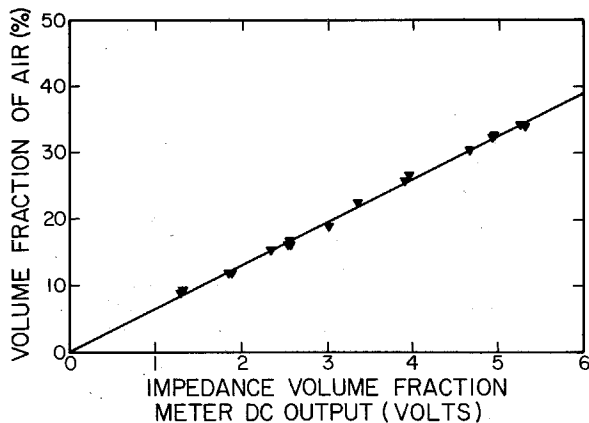

FIGURE 3 Calibration curve of the Impedance Volume Fraction Meter for a steady air-water bubbly flow in stagnant water.

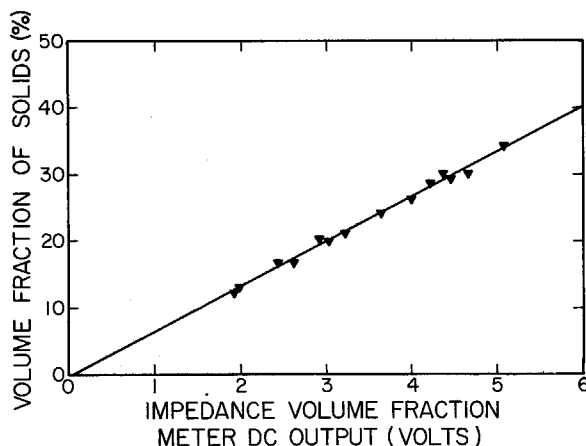

FIGURE 4 Calibration curve of the Impedance Volume Fraction Meter for a steady solids-water dispersed flow of zero total volume flow rate.

3. EXPERIMENTAL PROCEDURE

After initiation of each experiment, data was not taken for 30 seconds in order to permit passage of the initial transient. For each run, measurements were made of the air flow rate (using the orifice meter) and the liquid flow rate (measured with an electromagnetic flow meter). The IVFM d.c. output and the static pressure transducer output were monitored on a strip chart recorder. The IVFM a.c. component was also recorded on magnetic tape through a d.c. blocking amplifier with a 3dB cut off frequency of .032 Hz and a fall off slope of 10 dB per octave. The record length was five minutes whenever possible. The shortest record was of one minute which is of ample length for accurate determination of the mean square fluctuation. Visual observations were made of the nature of the flows and the flow pattern.

In two component flows, ν , the solids volume fraction or α , the air volume fraction is directly obtained from the IVFM. At low flow rates α or ν is also given by the output of the differential pressure transducer since the frictional component of the pressure drop is very small. Indeed this is how the calibrations (1) and (2) were obtained. In a three component flow at low flow rates, the differential static pressure transducer yields the bulk density which is a function of the individual volume fractions of air and solids. The mean IVFM d.c. output gives the sum of the air and solid volume fractions. Thus we can deduce the concentration of the individual constituents.

The size distribution of a multicomponent flowing medium influences the statistical properties of the fluctuating component of volume fraction signals. For example, for two flows of equal volume fraction, the one with large particles will yield less frequent and larger fluctuations than the one with very small particles. In this paper we use the IVFM Signal To Noise Ratio (STNR) to represent the nature of the fluctuating volume fraction signal. The STNR is defined as the ratio of the mean voltage to the root mean square of the fluctuating component of the IVFM output. A Hewlett Packard 3562 spectral analyser was used to obtain mean square values of the fluctuating component of the volume fraction signals. The Auto Correlation Function (ACF) at time zero yielded the mean square value of the input signal. 50 ensemble averages of the ACF proved to be adequate to give a repeatable value of the mean square voltage. With a chosen time scale of one second for each ensemble a record length of 60 seconds was required to complete the reduction.

4. FLOW PATTERN OBSERVATIONS

As a complement to the data on the fluctuations of volume fraction signals, the following observations were made for air-water, particle-water and air-particle-water flow. The accessible flow rates are constrained by flooding of either the solid or the gas phase. The total flux was restricted between -0.1 m/s and 0.2 m/s.

The air-water flows are homogeneously dispersed at low air volume fractions with a photographically measured average bubble size of 4 mm and a deviation of up to .5 mm from the mean. The flow remains dispersed up to a volume fraction of 40 % (fig. 5). With increased air injection the flow becomes intermittently agitated with the formation of large bubbles. This flow is said to be churn-turbulent (fig. 6). Transition from bubbly flow to churn-turbulent is observed to happen more suddenly than the change in the opposite direction. The flow takes of the order of minutes to settle down to the bubbly state of 35 % volume fraction at constant air flow rate. The change in regime has the notable effect of preventing the volume fraction from ever rising above 45 % under our experimental conditions.

The particle-water flows are well dispersed for low volume fractions (fig. 7). For the low total flow rates considered, the flow never develops any unsteady vortical structure. At high particle concentrations (55 %), the particles can no longer move relative to one another and the two component medium appears to translate like a solid plug inside the pipe. This is referred to as plug flow (fig. 8).

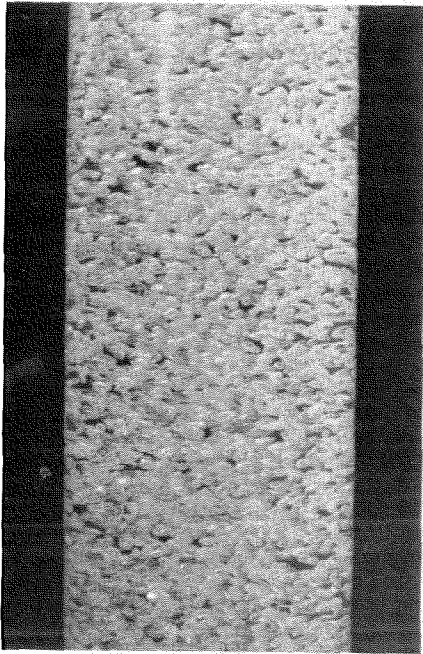

FIGURE 5 Bubbly air-water flow of 8 % volume fraction.

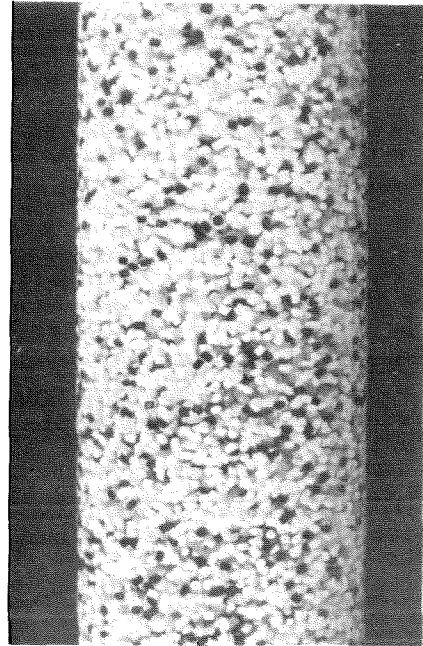

FIGURE 7 Dispersed solids-water flow of 12 % volume fraction.

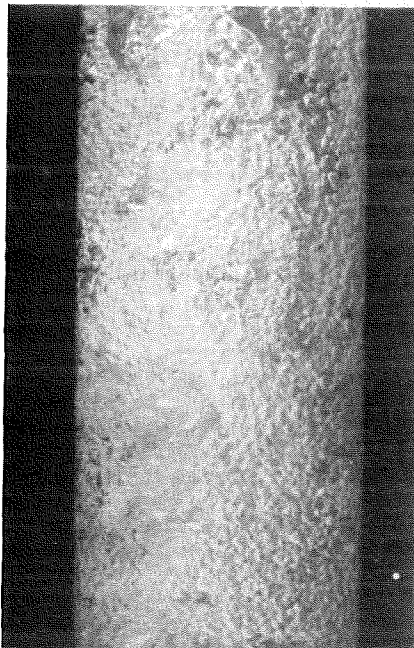

FIGURE 6 Churn-turbulent air-water flow of 37 % volume fraction.

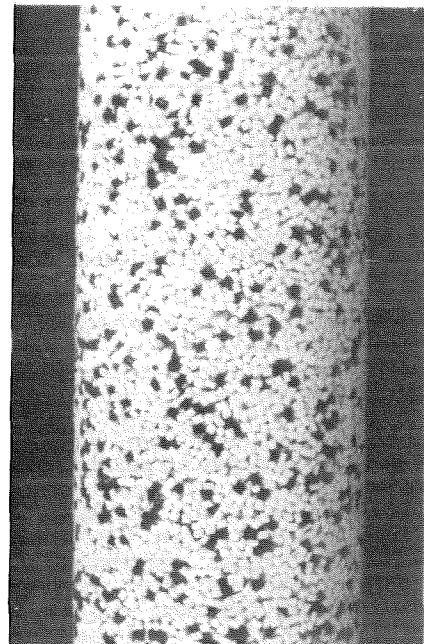

FIGURE 8 Solids-water plug flow of 55 % volume fraction.

Solids-liquid flows without air injection produce some audible noise due to particle-particle and particle wall collisions. One of the distinctive characteristics of three component flows is the dramatic increase in the level of this audible noise for all void and solid fractions considered. This is an indirect indication of an increase in the dispersed medium pressure caused by bubble-particle interactions. This effect demonstrates the enhanced erosive property of three component flows over two component flows. The dominant feature of the flows considered is the presence of large vortex structures in the solid component (fig. 9). These vortical structures have a typical dimension of the same order as the pipe diameter. At high solid volume fractions the air flow is not visible, indicating that the bubbles tend to flow in the central region of the pipe. At larger air flow rates, air slugs do however become visible (fig. 10).

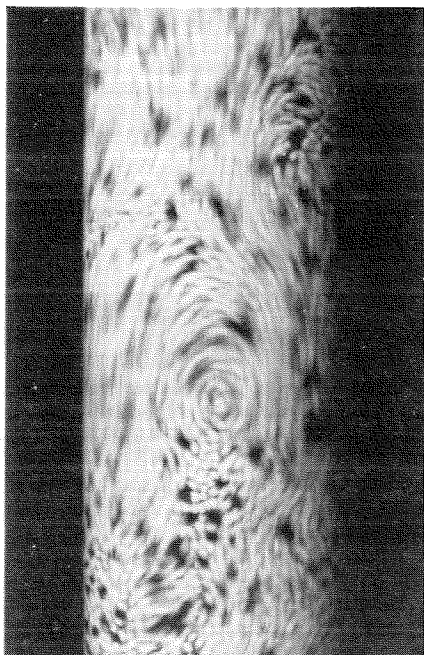

FIGURE 9 Three component flow of 30 % solids fraction and 15 % void fraction, showing large vortex structure. 1/30 second exposure was used.

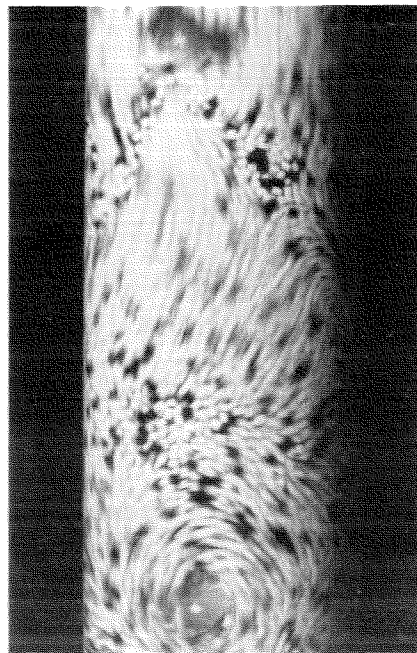

FIGURE 10 Three component flow of 22 % solids fraction and 20 % void fraction, showing large vortex structure and air slugs. 1/30 second exposure was used.

5. FLUCTUATING VOLUME FRACTION SIGNALS

The Signal To Noise Ratio (STNR) of the IVFM was derived by dividing the mean IVFM output by the root mean square value of the fluctuating component of the signal. In air-water flows, as the volume fraction is increased up to 40 %, the STNR rises monotonically. Upon additional air injection, a sudden drop in signal to noise ratio is experienced along with a decrease in volume fraction as shown in figure 11. The drop in STNR is caused by the formation of slugs of air; the accompanying drop in void fraction is caused by corresponding increase in mean relative velocity since the air flow rate is fixed. The results show that there are two stable values of signal to noise ratio for void fractions between 35 % and 45 %. Since the air-water experiments are carried out by fixing the air flow rate, the flow adjusts itself to one of these void fractions.

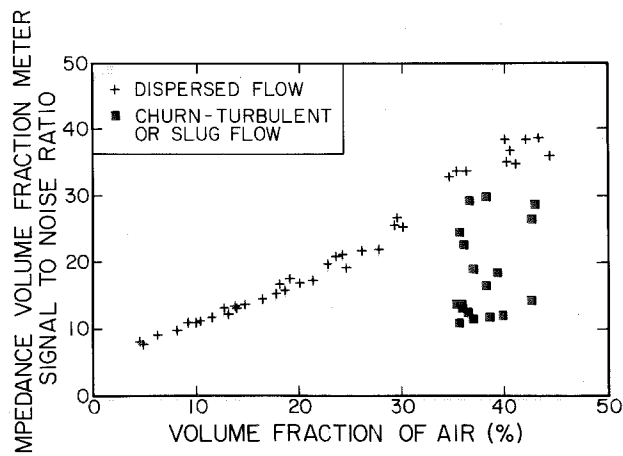

FIGURE 11 Impedance Volume Fraction Meter output Signal To Noise Ratio versus volume fraction for bubbly and churn-turbulent air-water flows.

The signal to noise ratio for particle flows (figure 12) is found to increase monotonically throughout the range of solid fraction. It is remarkable that this curve corresponds closely with the same curve for dispersed or bubbly air flows. Let us therefore call this the dispersed flow STNR curve.

The three component flows studied were all found to have large unsteady structure unlike the well behaved dispersed flows. The typical dimension of these vortices was of the order of the pipe diameter. The corresponding values of STNR are all below the dispersed flow values confirming our visual observation of the departure from orderly dispersed flow (figure 13). The

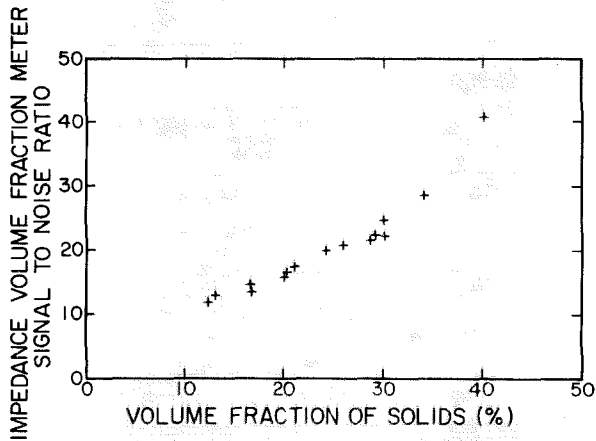

FIGURE 12 Impedance Volume Fraction Meter output Signal To Noise Ratio versus volume fraction for solids-water flows.

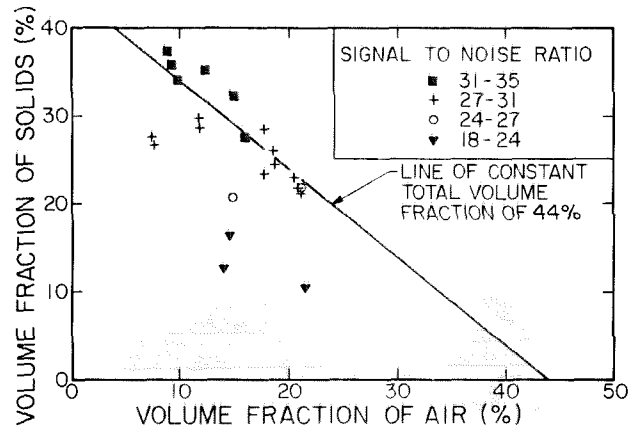

FIGURE 14 Map of three component flow solids fraction - void fraction combinations studied. The STNR is encoded in the symbol used.

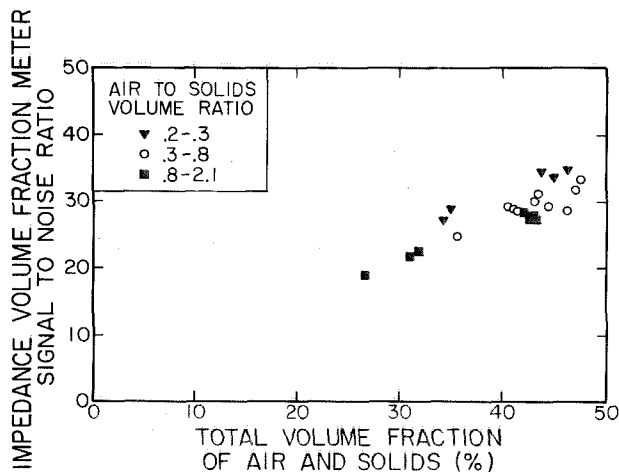

FIGURE 13 Impedance Volume Fraction Meter output Signal To Noise Ratio versus total volume fraction for three component air-solids-water flows.

air to solids ratio is used as a parameter in this figure. We find that for a given value of total volume fraction, the larger the air to solids ratio, the smaller the STNR. This result indicates that the air flow is responsible for the increase in volume fraction signal fluctuation by the formation of larger bubbles (slugs). The departure of the STNR from dispersed flow values is noticeable before the slugs can be visually observed, and occurs at values of air volume fraction as low as 10%. Figure 14 shows a map of the solid and air volume fraction combinations studied with the STNR encoded in the symbol used for each point. A line of constant total volume fraction (= 44%) is drawn to demonstrate the variation in STNR with the air volume fraction. Along this line all points with an air content of less than 15% have an STNR above 31. On the other hand all points of higher air content fall short

of 31 in SNTR. This shows that constant total volume fraction flows have larger volume fraction fluctuations with larger air content. This agrees with increased agitation observed at the higher air flow rates.

6. ERROR CONTENT IN MEASUREMENTS

The IVFM measurement of volume fraction is found to be linear and very repeatable for dispersed flows, with an error of no more than $\pm 2\%$. The linearity is preserved up to at least 40% volume fractions. In churn-turbulent and slug flows of two and three component media, the uncertainty (scatter) in the volume fraction measurement rises to $\pm 5\%$. Accurate measurement of volume fraction based on the IVFM d.c. output relies on an adequate calibration which can vary with time. The STNR on the other hand can be used to monitor volume fraction without required repeated calibration. The STNR is independent of the IVFM sensitivity to volume fraction since both the r.m.s. of the fluctuating part of IVFM signal and the average d.c. component are scaled according to the linear calibration slope. The dispersed STNR curve (figs. 11 & 12) provides a volume fraction measurement of $\pm 5\%$ accuracy. The STNR lends itself to reliable volume fraction measurement in situations where regular calibration is inconvenient, at the cost of a nonlinear STNR - volume fraction relation.

7. CONCLUSIONS

The signal to noise versus volume fraction data for slurry and dispersed air-water two-component flows fall on a single well defined curve (figures 11 & 12). This result shows that the STNR could be used as a second means of measuring volume fraction in dispersed flows. The STNR, in conjunction with the mean volume fraction, provides a flow regime delimiting tool capable of differentiation between dispersed bubbly and churn-turbulent flows. Solids-water flows are shown to undergo quite a different transition in regime from dispersed to plug flow. The solid like plug flow displays no agitation and correspondingly yields high values of STNR.

In this preliminary study of the statistical properties of three-phase volume fraction signals the most surprising result is the apparent absence of dispersed air-solid-water flows over the range of conditions considered. Rather, the solid flow assumes a vortical structure and the air flow forms large bubbles. The three-phase STNR is found to be sensitive to flow regime and to noticeably decrease with the increased agitation in the flow. It can therefore be used as an indicator of the nature of the flow.

ACKNOWLEDGEMENTS

The authors wish to thank Danamichele Brennen for help with the experiment and data reduction.

REFERENCES

1. Ishagai, S., Yamane, M. & Roko, K., "Measurement of the Component Flows in a Vertical Two-Phase Flow by making use of the Pressure Fluctuations", Bull. J.S.M.E., 8, 1965, 375-390.
2. Jones, O.C. & Zuber, N., "The Interrelation between Void Fraction Fluctuations and Flow Patterns in Two-Phase Flows", Int. J. Multiphase Flow, 2, 1975, 273-306.
3. Bernier, R.J.N., "Unsteady Two-Phase Flow Instrumentation and Measurement", Ph.D. Thesis, California Institute of Technology, September 1981.
4. Fessas Y.P. & Weiland R.H., "Convective Solids Settling Induced by a Buoyant Phase", A.I.Ch.E. Journal, 27, 1981, 588-592.