

MEASUREMENTS OF THE ROTORDYNAMIC SHROUD FORCES FOR CENTRIFUGAL PUMPS

A. Guinzburg, C. E. Brennen, A. J. Acosta, and T. K. Caughey
California Institute of Technology
Pasadena, California

ABSTRACT

An experiment was designed to measure the rotordynamic shroud forces on a centrifugal pump impeller. The measurements were done for various whirl/impeller speed ratios and for different flow rates. A destabilising tangential force was measured for small positive whirl ratios and this force decreased with increasing flow rate.

NOMENCLATURE

[A]	rotordynamic matrix
b	width of the leakage path, clearance
F(t)	hydrodynamic forces
R	radius
t	time
x(t)	instantaneous displacement in the x direction
y(t)	instantaneous displacement in the y direction
δ	offset of the center of the whirl orbit from the center of the casing.
ϵ	eccentricity of the whirl motion
ρ	density of the fluid
ω	rotor frequency
Ω	whirl frequency

Subscripts

o	steady
1	leakage flow discharge (pump inlet)
2	leakage flow inlet (pump outlet)
n	normal to the whirl orbit
t	tangential to the whirl orbit
x	along the x axis
y	along the y axis

INTRODUCTION

This research stems from concern with the fluid induced rotordynamic forces on impellers in turbomachines, specifically centrifugal pumps. It has been recognized for some time that asymmetries in the flow through an impeller can cause significant radial loads (Iverson et al, 1960; Chamieh et al, 1985). However, the fluid-induced rotordynamic forces and force matrices have not been addressed until recently. In the Rotor Force Test Facility (RFTF) at Caltech (Jery et al, 1985; Adkins et al, 1988; Franz et al, 1989) known whirl motions over a full range of frequencies (subsynchronous, supersynchronous as well as reverse whirl) are superimposed on the normal motion of an impeller. The unsteady forces imposed by the whirl on the impeller are then measured by means of a six-component dynamic force balance onto which the impellers are directly mounted (Jery et al, 1986). These measurements are processed to find not only the steady forces due to volute asymmetry, but also the unsteady rotordynamic forces and matrices.

Most significantly it was discovered that for centrifugal pumps there exists a range of subsynchronous whirl speeds for which the fluid forces acting on the impeller are rotordynamically destabilizing. Moreover, the work of Jery et al(1985) and Adkins et al(1988) on centrifugal pump impellers demonstrated that there are two sources for those fluid-induced forces. First circumferential nonuniformity in the pressure of the main throughflow at the discharge leads to both radial and rotordynamic forces. In addition Adkins et al(1988) demonstrated both analytically and experimentally that the leakage flow from discharge through the gap outside the impeller shroud to the inlet was responsible for significant nonuniformity in the pressure acting on the exterior of the shroud and that this contributed to both the radial forces and rotordynamic matrices. About the same time, Childs(1986) generated an analytical approach to the rotordynamic effects of these leakage flows by modifying the approach he had successfully developed for seals. Childs' theory yielded some unusual results including peaks in the rotordynamic forces at particular positive whirl ratios, a phenomenon which Childs tentatively described as a "resonance" of the leakage flow.

The purpose of the present work is to investigate these shroud forces experimentally. It is of particular interest to compare Childs' theoretical predictions with the experimental observations.

EXPERIMENTAL APPARATUS

An experimental apparatus was designed and constructed to simulate the impeller shroud leakage flow (Zhuang, 1989). A schematic of the installation in the RFTF is shown in Figure 1. A rotating shroud is mounted on a spindle attached to the rotating force balance (Jery et al, 1985; Franz et al, 1989). The gap between this rotating shroud and the stationary casing can be varied by both axial and radial adjustment of the casing. The initial geometric configuration consists of a straight annular gap inclined at an angle of 45° to the axis of rotation. The flow through the leakage path (in either direction) is generated by an auxiliary pump. The shroud can be driven at speeds up to 3500 RPM. A circular whirl motion with a frequency up to 1800 RPM can be superimposed on the basic rotation. The amplitude of this whirl motion or eccentricity can be varied but the results presented here were obtained with a 1.25mm(0.010 inch) eccentricity. In addition, arrays of static pressure manometer taps along meridians are located at three different circumferential locations. Flush-mounted dynamic response pressure transducers can also be installed. Thus the potential experimental measurements include:

- (i) the overall radial forces and rotordynamic matrices acting on the rotating shroud measured using the force balance.
- (ii) the steady and unsteady pressure profiles in the leakage path.

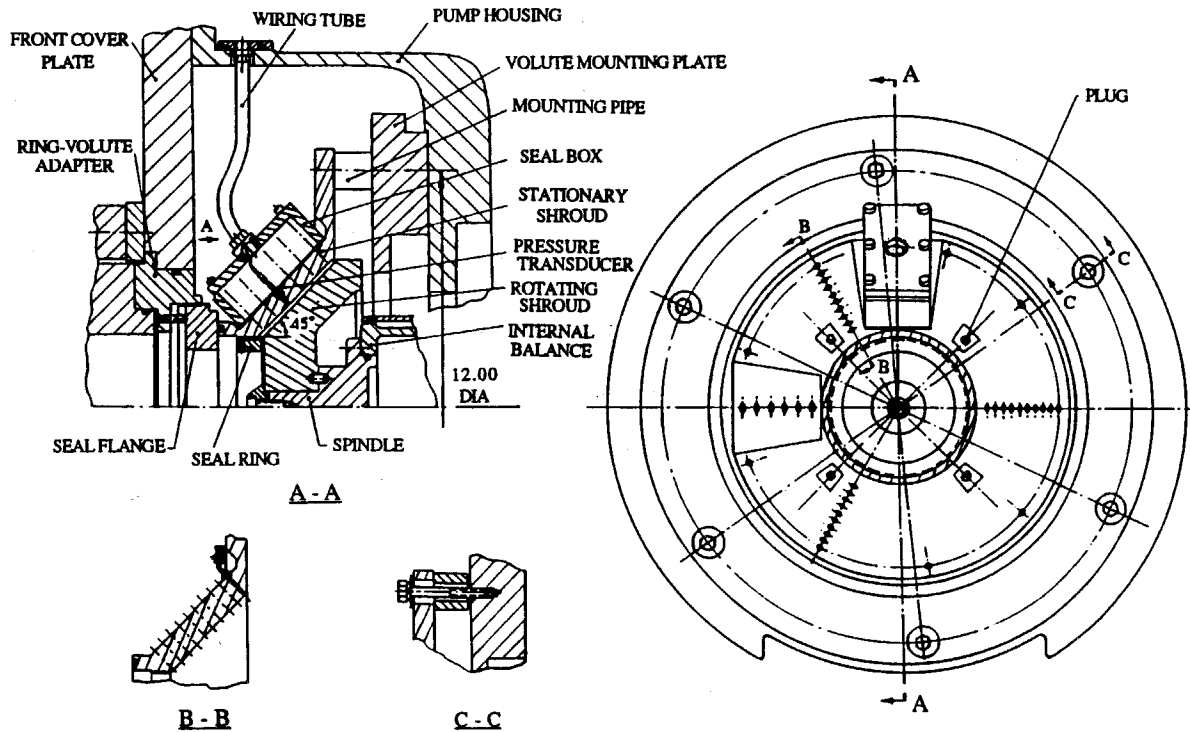

FIGURE 1a. Layout of the RFTF installation for investigation of the shroud forces and leakage path dynamics.

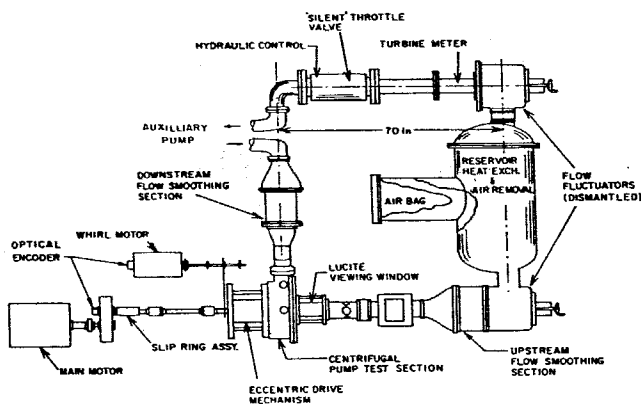

FIGURE 1b. Schematic of the Rotor Force Test Facility (RFTF).

The parameters of these experiments include Reynolds number, flow coefficient (ratio of typical flow velocity to rotating velocity), shroud clearance, eccentricity, and whirl ratios (ratio of whirl frequency to rotating frequency). Also concentric and nonconcentric circular whirl orbits could be investigated. Some preliminary results will be presented here.

The hydrodynamic force on a rotating shroud or impeller (see figure 2) which is whirling can be expressed in the stationary frame in linear form as:

$$\begin{bmatrix} F_x(t) \\ F_y(t) \end{bmatrix} = \begin{bmatrix} F_{ox}(t) \\ F_{oy}(t) \end{bmatrix} + [A] \begin{bmatrix} x(t) \\ y(t) \end{bmatrix} \quad (1)$$

The first term on the right hand side represents the radial force in the absence of whirl motion. The matrix [A] is the rotordynamic matrix which operates on the instantaneous displacement [x] of the rotor center. Note that [A] will in general be a function not only of the mean flow conditions but also of the frequency of whirl, Ω . If outside the linear range, it may also be a function of the amplitude of the whirl motion, ϵ . The forces normal and tangential to the imposed circular whirl orbit are related to the matrix elements as follows:

$$\begin{aligned} F_n(t) &= 1/2(A_{xx} + A_{yy})\epsilon \\ F_t(t) &= 1/2(-A_{xy} + A_{yx})\epsilon \end{aligned} \quad (2)$$

The reader is referred to Jery et al (1985) and Franz et al (1989) for details.

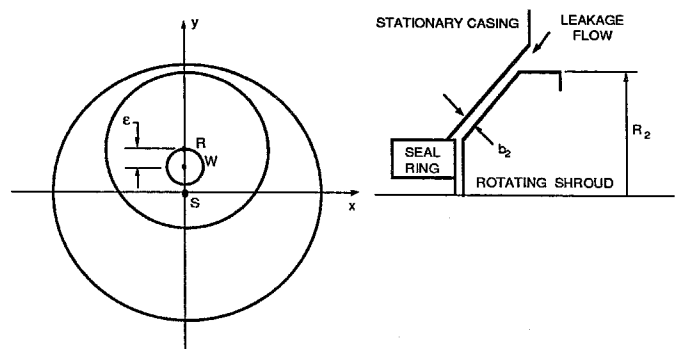

FIGURE 2a. Schematic of the whirling shroud where S is the center of the stationary casing, R is the center of the rotating shroud, W is the center of the whirl orbit along which R travels, $WR = \epsilon$ is the eccentricity, and $WS = \delta$ is the offset.

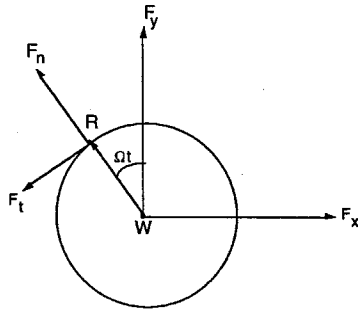

FIGURE 2b. Lateral forces on the shroud whirling in a circular orbit (see figure 2a). F_x and F_y represent the instantaneous forces in the stationary laboratory frame. F_n and F_t are the forces normal and tangential to the whirl orbit.

DISCUSSION OF RESULTS

A sample of the data obtained for the shroud rotation speed of 1000 RPM is presented in figures 3 and 4. The mean clearance between the shroud and the housing is 1.40mm. The inlet leakage flow radius is 93.66mm and the whirl radius is 0.254mm. The steady forces F_{ox} and F_{oy} are temporal and spatial averages of the lateral forces sensed by the dynamometer and hence they should be independent of the whirl ratio. Their magnitude is small compared to the unsteady forces because the steady forces only occur due to the offset and other minor asymmetries. In the idealised case where the rotating shroud is perfectly centered, the steady forces should be zero.

The unsteady forces F_n and F_t are normalized by the dynamic head, $\rho(\omega R_2)^2 \pi R_2 b_2 \epsilon / R_2$. The shape of the curve for the normal force, F_n (figure 3) is qualitatively similar to that of Jery et al (1985), Franz et al (1989) and Childs (1986). The parabolic shape may be attributed to the added mass of the fluid. The data shown is for zero flow rate; very similar data was obtained with non-zero flow rates up to $1.89 \times 10^{-3} \text{ m}^3/\text{s}$.

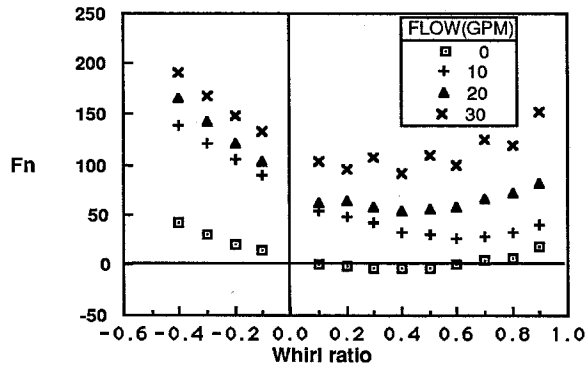

FIGURE 3. Normalised normal force F_n on the shroud rotating at 1000RPM for different flowrates. The eccentricity of the whirl orbit is 0.254mm. The clearance is 1.40mm.

From the point of view of rotordynamics, the unsteady tangential force F_t is usually of greater importance. Tangential forces for no flow and flow are depicted in figure 4. A tangential force in the direction of whirl motion will encourage the motion and is therefore destabilizing. From figure 4 it can be seen that these leakage flows produce a positive tangential force at small positive whirl ratios indicating destabilizing fluid forces. It should be noted that the F_t is complicated and changes sign more than once for the no flow case. Similar behavior has been observed by Jery et al (1986) on a centrifugal pump. For negative whirl ratios, the force is positive and therefore stabilizing. The non-dimensional force coefficients presented by Childs (1986) also show unexpected negative troughs in the radial force coefficients and positive peaks in the tangential force coefficients, which Childs describes as "resonance" of the leakage flow.

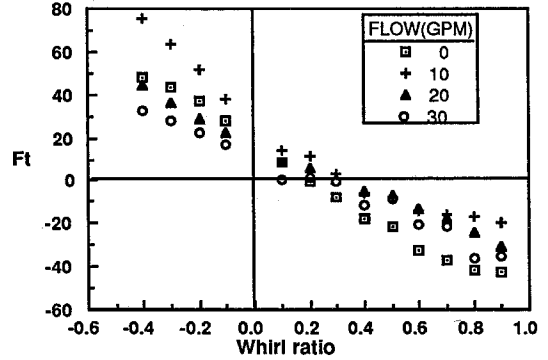

FIGURE 4. Normalised tangential force F_t under the same conditions as figure 3 and for various flow rates as shown.

The effect of the flow rate is shown in figure 4 where data is included for no flow and for $6.31 \times 10^{-4} \text{ m}^3/\text{s}$ (10 GPM), $1.26 \times 10^{-3} \text{ m}^3/\text{s}$ (20 GPM) and $1.89 \times 10^{-3} \text{ m}^3/\text{s}$ (30 GPM). It can be seen that at both positive and negative whirl ratios, the force decreases with increasing flow. Thus at positive whirl ratios increasing the flow tends to cause increased stability. Increasing the clearance between the shroud and the casing decreases the normal and the tangential force and this is shown in figures 5 and 6.

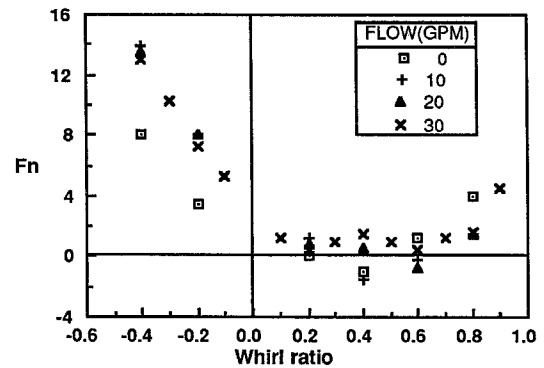

FIGURE 5 Normalised normal force F_n on the shroud rotating at 1000RPM for different flowrates. The eccentricity of the whirl orbit is 0.254mm. The clearance is 4.24mm.

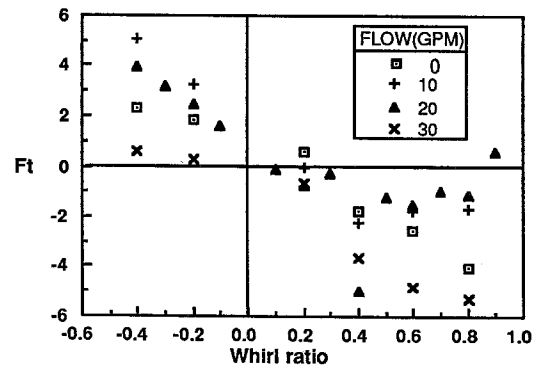

FIGURE 6 Normalised tangential force F_t under the same conditions as figure 5 and for various flow rates as shown.

It is interesting to compare the magnitudes of the forces with previous results obtained for a real centrifugal impeller in the same facility. The data for Franz et al (1989) on a Byron Jackson centrifugal pump was obtained with an eccentricity of 1.25mm which is significantly larger than the present value of 0.254mm. Thus, it is appropriate to compare the "stiffnesses" F_n/ϵ and F_t/ϵ . At zero whirl ratio the present data for the clearances of 1.40mm (and 4.24mm), yields values of 2.8KN/m (and .46KN/m) and 7.6KN/m (and 1.88KN/m) respectively compared to 6.8KN/m and 2.28KN/m for the data of Franz et al (1989). Though the geometries of the leakage pathways are quite different this still suggests that the contribution of the shroud leakage flow to the rotordynamic forces may be substantial.

Adkins and Brennen (1988) attempted to separately evaluate the rotordynamic forces on the discharge and on the shroud of a centrifugal pump. Chamieh et al (1983) had earlier measured the total rotordynamic force on a particular impeller/volute combination and obtained values of 6.0KN/m and 2.7KN/m for F_n/ϵ and F_t/ϵ , at zero whirl ratio. Adkins and Brennen (1988) substantially increased the size of the gap external to the shroud for this impeller/volute combination and obtained altered values of 4.8KN/m and 0.9KN/m for F_n/ϵ and F_t/ϵ . This reduction implied a significant contribution from the shroud forces. Although the difference between the two leakage flow measurements is of the same order of magnitude as the present results, the geometries of the leakage flows are quite different. Detailed comparisons will be made in the future.

In conclusion we remark that this paper reports on work in progress and that further data will be presented at the conference.

ACKNOWLEDGEMENTS

The authors would like to thank A. Bhattacharyya, F. Rahman and F. Zhuang for their help in conducting the experiments. This work is supported by NASA George C. Marshall Space Flight Center, Huntsville, Alabama under NASA grant No NAG8-118: the authors are grateful for this support.

REFERENCES

- Adkins, D.R., and Brennen, C.E., 1988, "Analyses of Hydrodynamic Radial Forces on Centrifugal Pump Impellers," ASME Journal of Fluids Engineering, Vol. 110, No. 1, pp20-28.
- Chamieh, D.S., 1983, "Forces on a Whirling Centrifugal Pump-Impeller," Ph.D. Thesis, Division of Engineering and Applied Science, California Institute of Technology, Pasadena, CA.
- Chamieh, D.S., Acosta, A.J., Brennen, C.E., Caughey, T.K., 1985, "Experimental Measurements of Hydrodynamic Radial Forces and Stiffness Matrices for a Centrifugal Pump-Impeller," ASME Journal of Fluids Engineering, Vol. 107, No.3, pp307-315.
- Childs, D.W., 1986, "Force and Moment Rotordynamic Coefficients for Pump-Impeller Shroud Surfaces," Proceedings of Advanced Earth-to-Orbit Propulsion Technology Conference, Huntsville, AL, May 1986, NASA Conf Publ. 2436, pp296-326
- Franz, R., Acosta, A.J., Brennen, C.E., Caughey, T.K., 1989, "The Rotordynamic Forces on a Centrifugal Pump Impeller in the Presence of Cavitation," Proceedings of 3rd Joint ASCE/ASME Mechanics Conference, UCSD, July 1989, Pumping Machinery, Vol81, pp205-212.
- Iversen, H.W., Rolling, R.E., and Carlson, J.J., 1960, "Volute Pressure Distribution, Radial Force on the Impeller and Volute Mixing Losses of a Radial Flow Centrifugal Pump," ASME Journal of Engineering for Power, Vol. 82, No. 2, pp136-144.
- Jery, B., Acosta, A.J., Brennen, C.E., and Caughey, T.K., 1985, "Forces on Centrifugal Pump Impellers," Second International Pump Symposium, Houston, Texas, April 29-May 2, 1985.
- Jery, B., 1986, "Experimental Study of Unsteady Hydrodynamic Force Matrices on Whirling Centrifugal Pump Impellers," Ph.D Thesis, California Institute of Technology.
- Zhuang, F., 1989, "Experimental Investigation of the Hydrodynamic Forces on the Shroud of a Centrifugal Pump Impeller," E249.9, 1989, Division of Engineering and Applied Science, California Institute of Technology.